

# Castle Nuts

## DIN 935-1

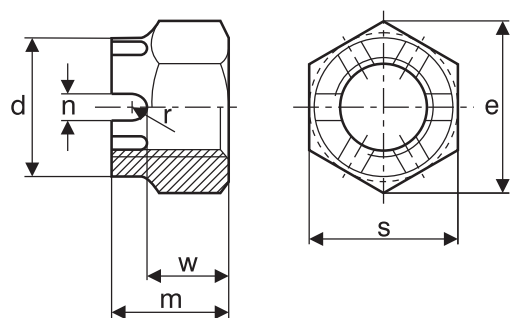

### DIN935-1 Dimensions of nuts

Nominal size and thread diameter d	p	d		e	m		n		s		w	
	(coarse pitch series)	max.	min.	min.	nom.	min.	min.	max.	nom.	min.	min.	max.
M12	1.75	16	15.57	20.03	15	14.57	3.5	3.80	18	17.73	9.64	10
M14	2.00	18	17.57	23.35	16	15.57	3.5	3.80	21	20.67	10.57	11
M16	2.00	22	21.48	26.75	19	18.48	4.5	4.80	24	23.67	12.57	13
M18	2.50	25	24.30	29.56	21	20.16	4.5	4.80	27	26.16	14.57	15
M20	2.50	28	27.30	32.95	22	21.16	4.5	4.80	30	29.16	15.57	16
M22	2.50	32	31.00	37.29	26	25.16	5.5	5.80	34	33.00	17.57	18
M24	3.00	34	33.00	39.55	27	26.16	5.5	5.80	36	35.00	18.48	19
M27	3.00	38	37.00	45.20	30	29.16	5.5	5.80	41	40.00	21.48	22
M30	3.50	42	41.00	50.85	33	32.00	7.0	7.36	46	45.00	23.48	24
M33	3.50	46	45.00	55.37	35	34.00	7.0	7.36	50	49.00	25.48	26
M36	4.00	50	49.00	60.79	38	37.00	7.0	7.36	55	53.80	28.48	29
M39	4.00	55	53.80	66.44	40	39.00	7.0	7.36	60	58.80	30.28	31
M42	4.50	58	56.80	71.30	46	45.00	9.0	9.36	65	63.10	33.38	34
M45	4.50	62	60.80	76.95	48	47.00	9.00	9.36	70	68.10	35.38	36
M48	5.00	65	63.80	82.60	50	49.00	9.00	9.36	75	73.10	37.38	38
M52	5.00	70	68.80	88.25	54	52.80	9.00	9.36	80	78.10	41.38	42
M56	5.50	75	73.80	93.56	57	55.80	9.00	9.36	85	82.80	44.38	45
M60	5.50	80	78.80	99.21	63	61.80	11.00	11.43	90	87.80	47.38	48
M64	6.00	85	83.60	104.86	66	64.80	11.00	11.43	95	92.80	50.26	51
M68	6.00	90	88.60	110.51	69	67.80	11.00	11.43	100	97.80	53.26	54
M72	6.00	95	93.60	116.16	73	71.80	11.00	11.43	105	102.80	57.26	58
M76	6.00	100	98.60	121.81	76	74.80	11.00	11.43	110	107.80	60.26	61
M80	6.00	105	103.60	127.46	79	77.80	11.00	11.43	115	112.80	63.26	64
M85	6.00	110	108.60	133.11	88	86.60	14.00	14.43	120	117.80	67.26	68
M90	6.00	120	118.60	144.08	92	90.60	14.00	14.43	130	127.50	71.26	72
M100	6.00	130	128.40	161.02	100	98.60	14.00	14.43	145	142.50	79.26	80

### Specification for nuts and reference standards

Characteristic		Standard
Material		Steel
General requirements	International Standards	ISO 8992
	Tolerance	6H <sup>a)</sup>
Thread	International Standard	DIN13-12 and DIN13-15
	Property Class (material)	For size up to M39: 6, 8 <sup>c)</sup> , 10 <sup>c)</sup> ; for larger sizes: as agreed
Mechanical Properties <sup>b)</sup>	As specified in	DIN EN 20898-2 and DIN EN ISO 898-6
	Product grade	For sizes up to M16: A; for larger sizes: B
Limit deviations and geometrical tolerances	As specified in	DIN EN ISO 4759-1
	Surface finish	As processed
		DIN EN ISO 4042 applies with regard to electroplating.
		DIN EN ISO 10683 applies with regard to zinc flake coatings.
		DIN 267-2 applies with regard to surface roughness.
		DIN EN 493 applies with regard to widening test and surface discontinuities.
Acceptance inspection		DIN EN ISO 3269 applies with regard to acceptance inspection.
<p>a Where an electroplated coating as specified in DIN EN ISO 4042 is to be applied, depending on the coating thickness required, it may be necessary, particularly in the the case of tolerance class 6H nuts, to select a larger fundamental deviation than that assigned to the H position. This, however, might impair the resistance of the bolt/nut assembly to stripping.</p> <p>b Where nuts are to be made of other materials or comply with other property classes, these shall be selected based on the relevant standards.</p> <p>c As a departure from DIN EN ISO 898-6, a minimum hardness of 272 HV 30 will be adequate for fine pitch thread nuts assigned to property classes 8 and 10.</p>		